

COMPONENTS • MANUFACTURING
ONE Trusted SOURCE
TESTING • ASSEMBLY

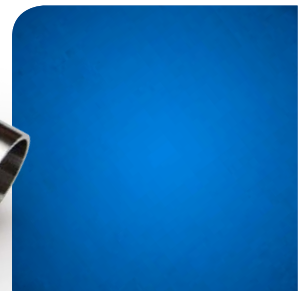

Process
Cooling Water



PCW
Ball Valves



Process Cooling
Water (PCW)
Ball Valves



PCW Applications

- Process Cooling Water (PCW), City Water, Potable Water

Product Description

- Size Range: NPS 1/2 to NPS 6
- Temperature Range: -20°F to 350°F (-29°C to 177°C)
- Pressure Rating:

NPS 1/2 – NPS 1-1/2:	1000 PSIG	(69 BARG)
NPS 2:	800 PSIG	(55 BARG)
NPS 3:	600 PSIG	(41 BARG)
NPS 4 – NPS 5:	500 PSIG	(34 BARG)
NPS 6:	300 PSIG	(21 BARG)
- Oil free stainless steel construction
- Available in various integrated tee valve assemblies

Features & Benefits

- High flow full-port design
- High cycle-life performance
- Floating ball for positive shut-off
- 3-Piece construction for ease of maintenance
- Locking handle for lock-out/tag-out applications
- 100% Leak tested and inspected
- Each valve includes a Certificate-of-Compliance to Valex specification SP-9236

Materials of Construction

PCW
Ball Valve

Item	Qty	Part	Material
A	1	BODY	CF8M SS
B	1	STEM PACKING	PTFE
C	1	STEM NUT	304/304L SS
D	1	HANDLE WASHER	300 SERIES SS
E	1	HANDLE NUT	300 SERIES SS
F	1	HANDLE	300 SERIES SS
G	1	HANDLE COVER	VINYL POLYMER
H	1	THRUST WASHER	PTFE
I	1	STEM	304/304L SS
J	2	SEAT	PTFE/RPTFE
K	2	BODY GASKET	PTFE
L	1	BALL	CF3M/CF8M/316/316L SS
M	2	END CAP FLANGE	CF3M/CF8M SS
N	4	END CAP FLANGE HARDWARE	300 SERIES SS

SS = Stainless Steel

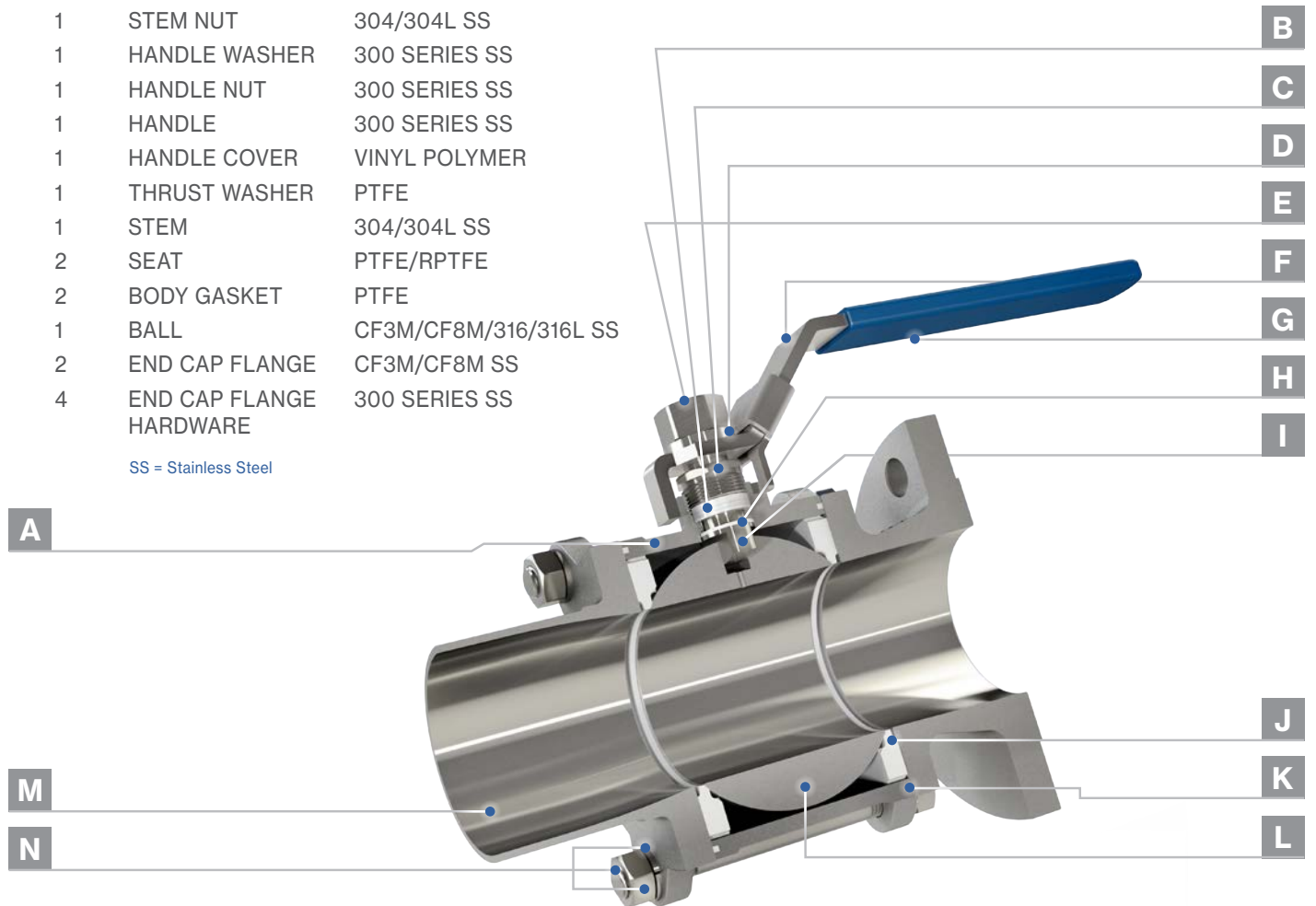

Pressure Temperature Rating

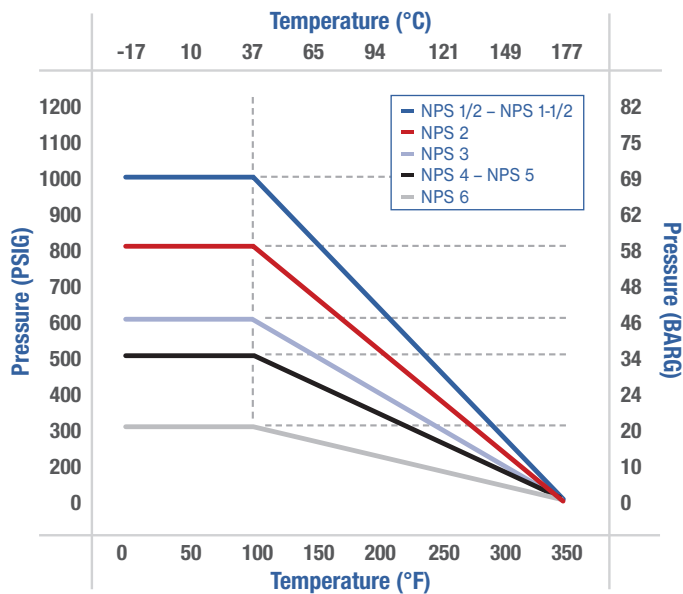

Flow Coefficient

Valve Size	Ball Orifice	Cv ¹
NPS 1/2	0.591"	37.0
NPS 3/4	0.787"	68.5
NPS 1	0.984"	110
NPS 1-1/4	1.260"	186
NPS 1-1/2	1.496"	269
NPS 2	1.969"	481
NPS 2-1/2	2.559"	839
NPS 3	3.150"	1,301
NPS 4	3.937"	2,085
NPS 5	4.921"	3,338
NPS 6	5.906"	4,902

1. Flow coefficient data calculated using methods described in Crane Technical Paper TP-410.

Dimensions

Custom Spools & Manifold Assemblies

Valex can build specialty PCW valve assemblies that reduce field welds and installation time.

From integrated tee valve sub-assemblies, all the way to 24 foot long PCW manifolds, Valex is your one trusted source for all of your PCW needs. Contact your local Valex representative for more details.

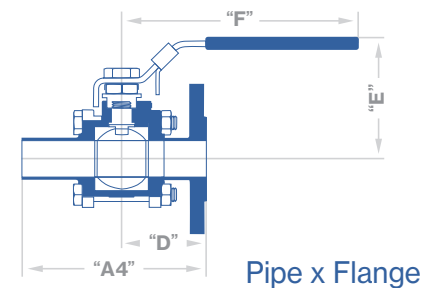
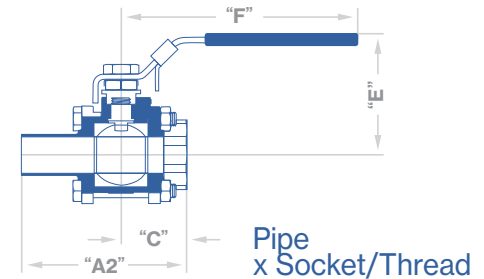
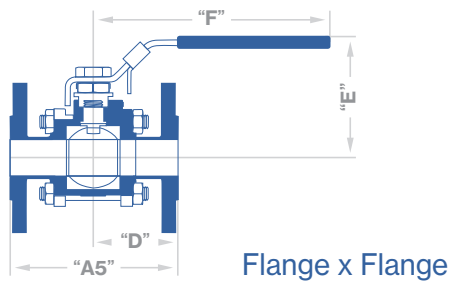
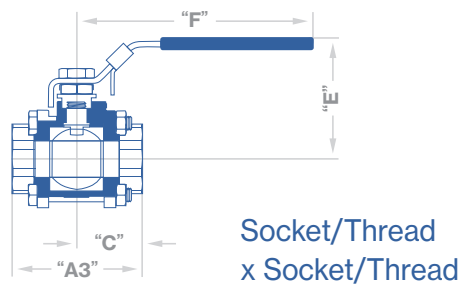
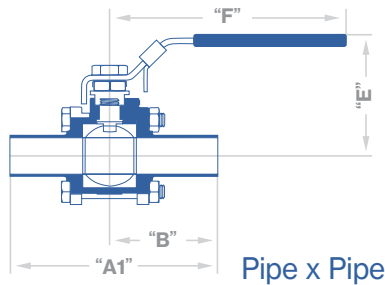

Dimensions in Millimeters*

Size	"A1"	"A2"	"A3"	"A4"	"A5"	"B"	"C"	"D"	"E"	"F"
NPS 1/2	135.4	105.2	75			67.7	37.5		59	105
NPS 3/4	135	107.5	80	126	117	67.5	40	58.5	65	133
NPS 1	152	121	90	139.5	127	76	45	63.5	74	159
NPS 1-1/4	157	133.5	110			78.5	55		78	159
NPS 1-1/2	190	155	120	194	198	95	60	99	91	198
NPS 2	208	172	140	218.5	229	104	70	114.5	99	198
NPS 2-1/2	254	219.5	185			127	92.5		137	260
NPS 3	280	242.5	205	263.7	247.4	140	102.5	123.7	149	260
NPS 4	306	273	240			153	120		186	288
NPS 5	320					160			198	325-650
NPS 6	376.4					188.2			N/A	Gear Operator

* Dimensions are approximate, subject to change, and may vary from valve to valve. Please check the Valex website for latest dimensions.



Standard Configurations

Straight Valve



Single Horizontal Cross



Double Horizontal Cross



Double Single Sided



Double Vertical Tee



Double Horizontal Tee



Benefit From World Leadership

We are your trusted source for high-purity ball valves, PCW ball valves, instrumentation ball valves, headers, manifolds, pipe, tube, fittings and more. For more information, please visit our website or contact your Vallex representative. Benefit from world leadership, and benefit from Vallex quality.





Ordering Information

P – S H C 7 7 L L 7 2 F X – B

P

Valve Series

P = Process Cooling Water (PCW)

S | H | C

Assembly Pattern

STR = Straight
 DHC = Double Horizontal Cross
 SHC = Single Horizontal Cross
 DSS = Double Single Sided
 DVT = Double Vertical Tee
 DHT = Double Horizontal Tee

7 | 7

Main Line Size

NPS Pipe

70 = DN 15 Pipe (NPS 1/2)
 71 = DN 20 Pipe (NPS 3/4)
 72 = DN 25 Pipe (NPS 1)
 73 = DN 32 Pipe (NPS 1-1/4)
 74 = DN 40 Pipe (NPS 1-1/2)
 75 = DN 50 Pipe (NPS 2)
 76 = DN 65 Pipe (NPS 2-1/2)
 77 = DN 80 Pipe (NPS 3)
 78 = DN 90 Pipe (NPS 3-1/2)
 79 = DN 100 Pipe (NPS 4)
 80 = DN 125 Pipe (NPS 5)
 81 = DN 150 Pipe (NPS 6)
 82 = DN 200 Pipe (NPS 8)

ASTM Tube

08 = 1/2"
 12 = 3/4"
 16 = 1"
 24 = 1-1/2"
 32 = 2"
 40 = 2-1/2"
 48 = 3"
 64 = 4"
 96 = 6"

L | L

Main Line End Connection

LL = NPS Sch 10 Pipe w/ Square Ends, Inlet & Outlet
 MM = Tube Butt weld Inlet & Outlet
 CC = Compression Fitting Inlet & Outlet
 FF = Class 150 Flange Inlet & Outlet
 SS = NPS Pipe Socket Weld Inlet & Outlet
 TT = NPS Female Pipe Thread Inlet & Outlet
 LF = NPS Sch 10 Pipe Inlet w/ Square End, Class 150 Flange Outlet
 LT = NPS Sch 10 Pipe Inlet w/ Square End, NPS Female Pipe Thread Outlet
 LS = NPS Sch 10 Pipe Inlet w/ Square End, NPS Pipe Socket Weld Outlet
 MF = Tube Butt weld Inlet, Class 150 Flange Outlet
 MT = Tube Butt weld Inlet, NPS Female Pipe Thread Outlet
 MS = Tube Butt weld Inlet, NPS Pipe Socket Weld Outlet
 MC = Tube Butt weld Inlet, Compression Fitting Outlet

7 | 2

Branch Valve Size

NPS Pipe

XX = No Branch Valve(s)
 70 = DN 15 Pipe (NPS 1/2)
 71 = DN 20 Pipe (NPS 3/4)
 72 = DN 25 Pipe (NPS 1)
 73 = DN 32 Pipe (NPS 1-1/4)
 74 = DN 40 Pipe (NPS 1-1/2)
 75 = DN 50 Pipe (NPS 2)
 76 = DN 65 Pipe (NPS 2-1/2)
 77 = DN 80 Pipe (NPS 3)
 78 = DN 90 Pipe (NPS 3-1/2)
 79 = DN 100 Pipe (NPS 4)
 80 = DN 125 Pipe (NPS 5)
 81 = DN 150 Pipe (NPS 6)

ASTM Tube

08 = 1/2"
 12 = 3/4"
 16 = 1"
 24 = 1-1/2"
 32 = 2"
 40 = 2-1/2"
 48 = 3"
 64 = 4"
 96 = 6"

F | X

Connection On Branch Valve(s)

XX = No Branch Valve
 LX = NPS Sch 10 Pipe, Square End
 MX = Tube Butt weld
 FX = Class 150 Flange
 TX = NPS Female Pipe Thread
 SX = NPS Pipe Socket Weld
 PX = Capped Compression Fitting

B

Handle Sleeve Color

0 = N/A
 B = Blue

Not all possible part number combinations are available. Please contact Valex for availability.



www.valex.com

**Valex Corporate
 Offices & Manufacturing**
 6080 Leland Street
 Ventura, CA 93003
 Phone: 805-658-0944

32, Hansan-Gil
 Chungbuk-Myon
 Pyongtaek-City
 Kyonggi-Province, Korea
 Phone: 86-31-683-0119

559 Yuanzhong Road
 Pudong New District
 Shanghai, China 201300
 Phone: 021-58183189



Neither ozone-depleting nor mercury-bearing compounds are used during Valex processing or testing of any product.